

Understanding Widening Participation & Fair Access to Higher Education

Tom Weaver

Widening Participation Officer, King's College London

Welcome

Tom Weaver

Widening Participation Officer

tom.weaver@kcl.ac.uk

020 7848 3899

@tom_king's

linkedin.com/in/tom-weaver/



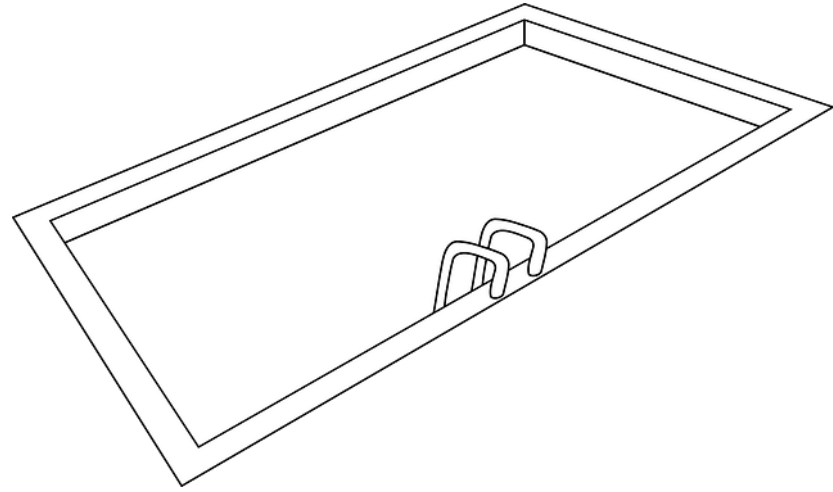

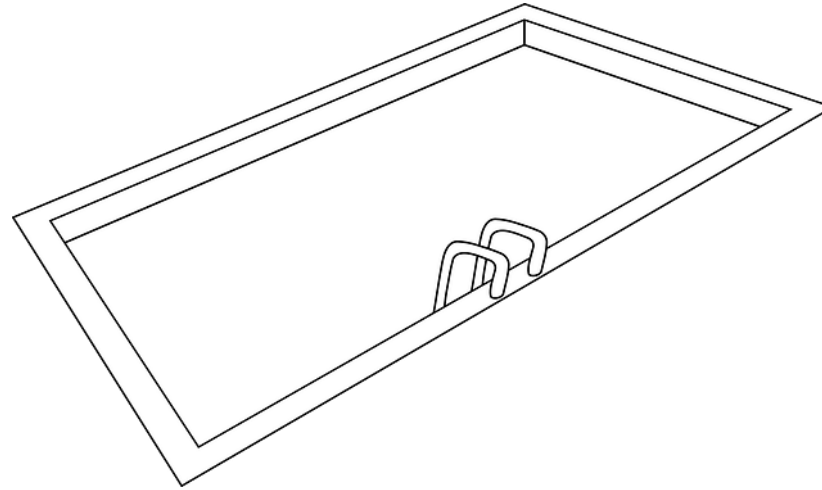

UNIVERSITY OF

LIVERPOOL

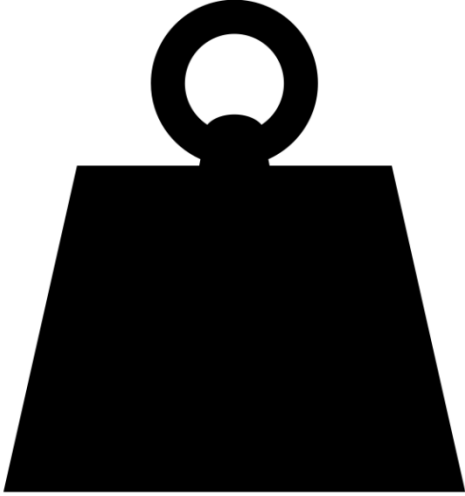
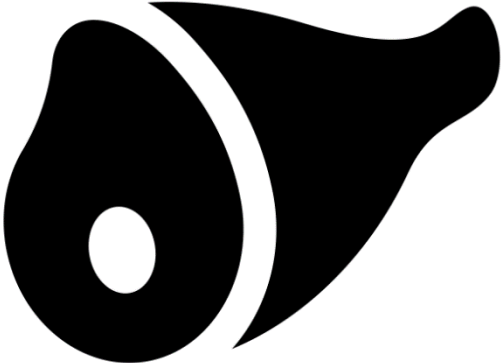
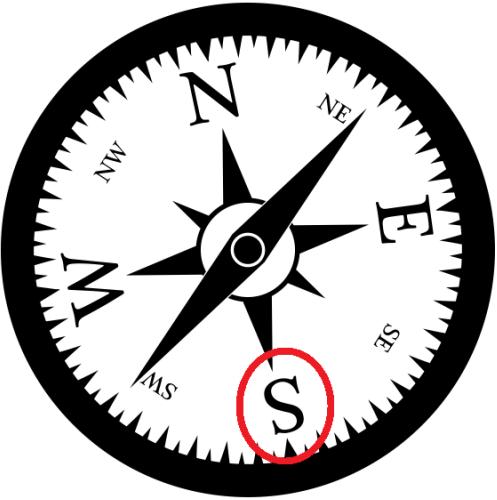

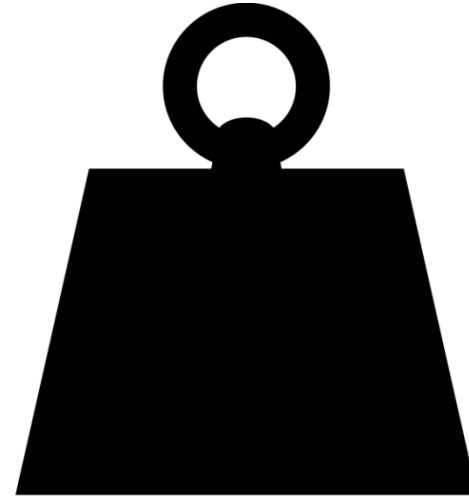
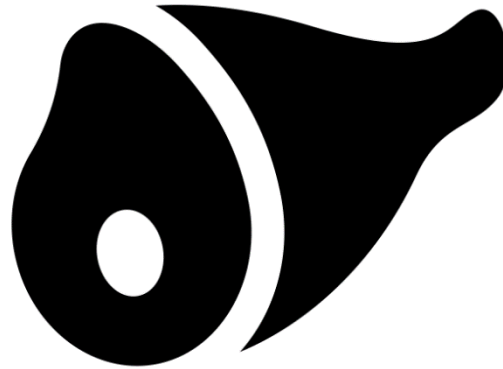
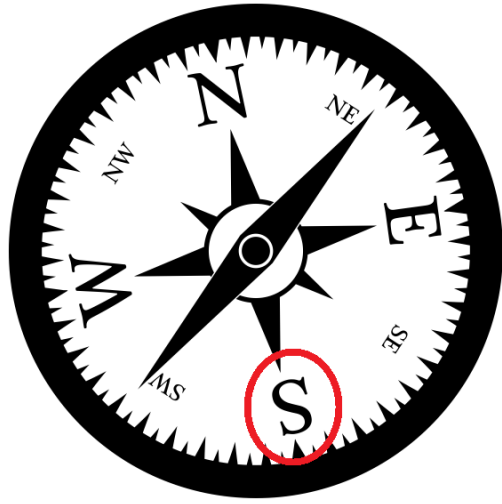

UNIVERSITY OF
Southampton

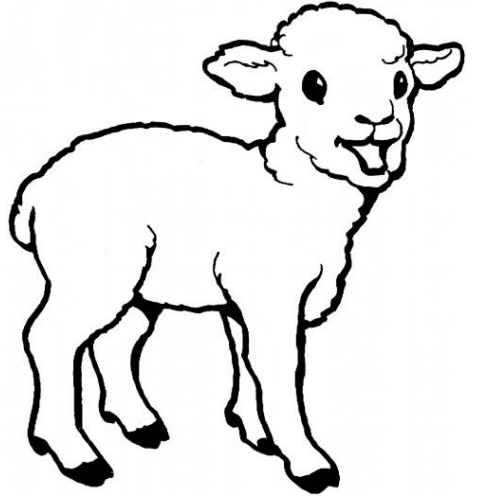
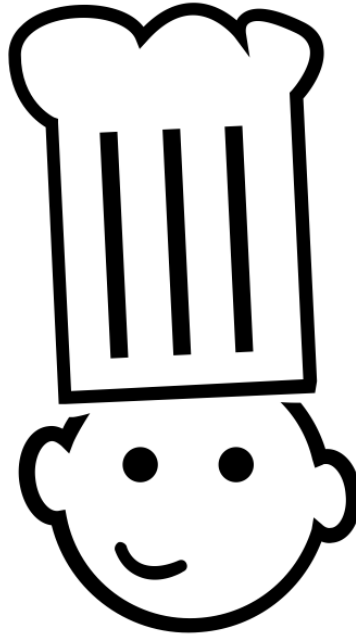

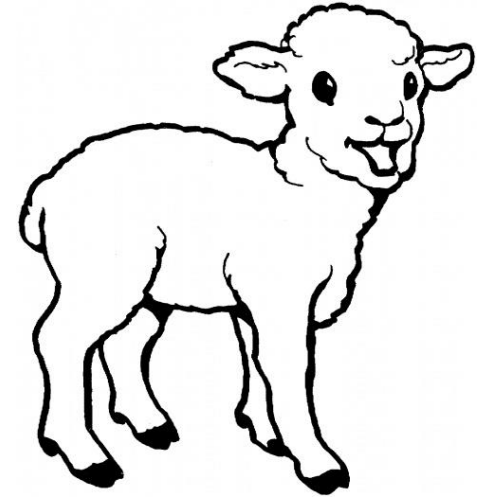
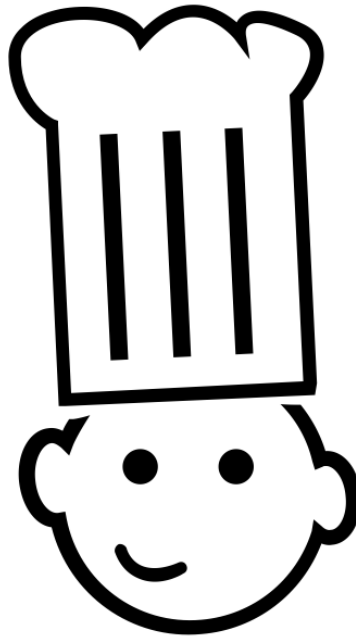

**Sheffield
Hallam
University**

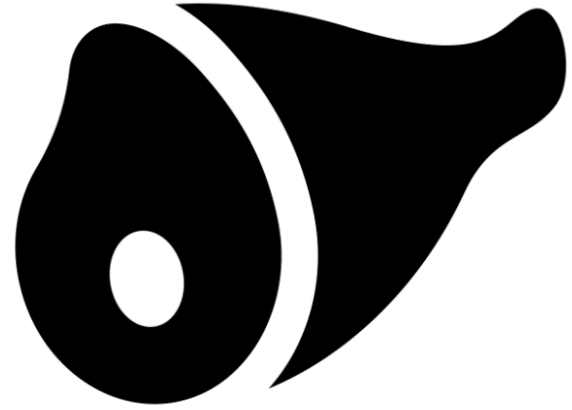
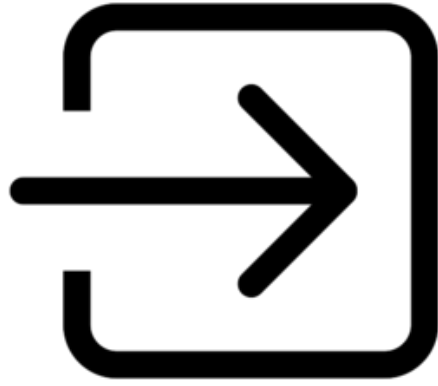
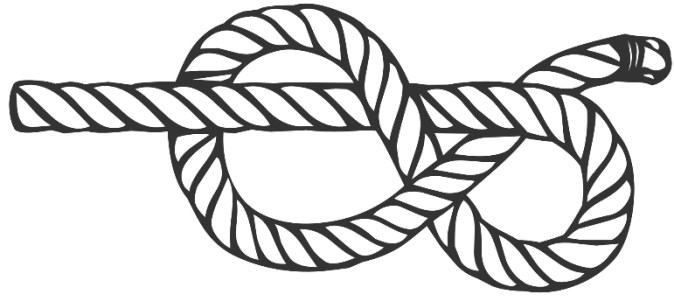

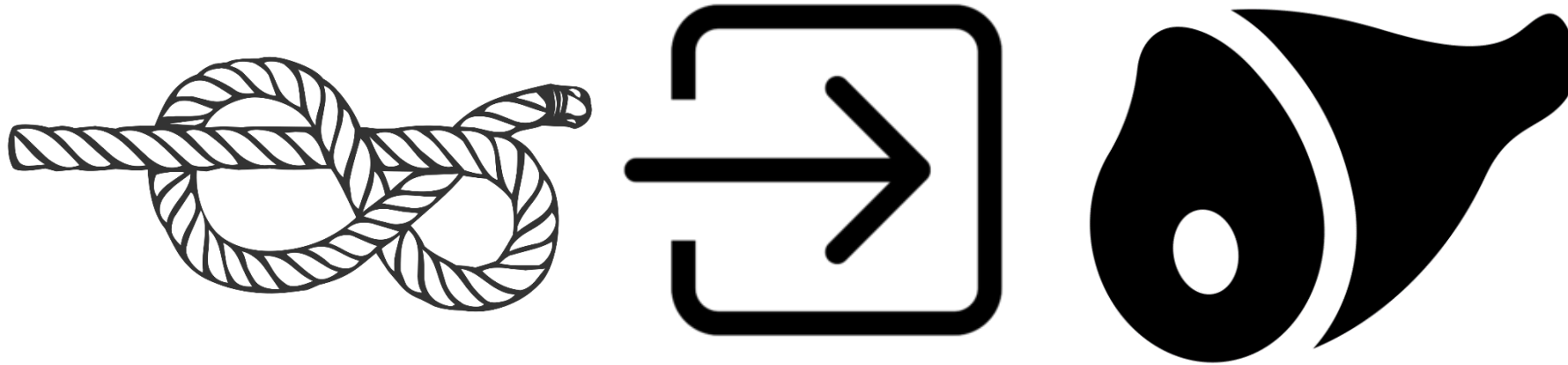

The University of
Nottingham

UNITED KINGDOM • CHINA • MALAYSIA

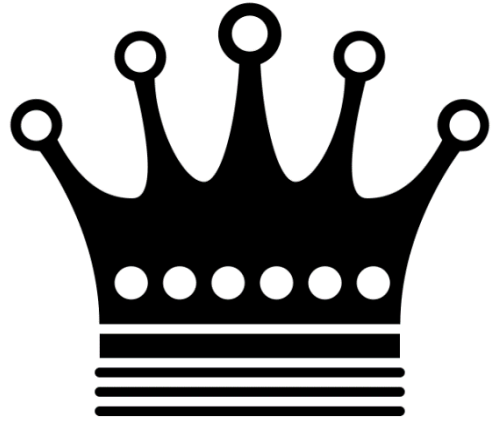



Introductions

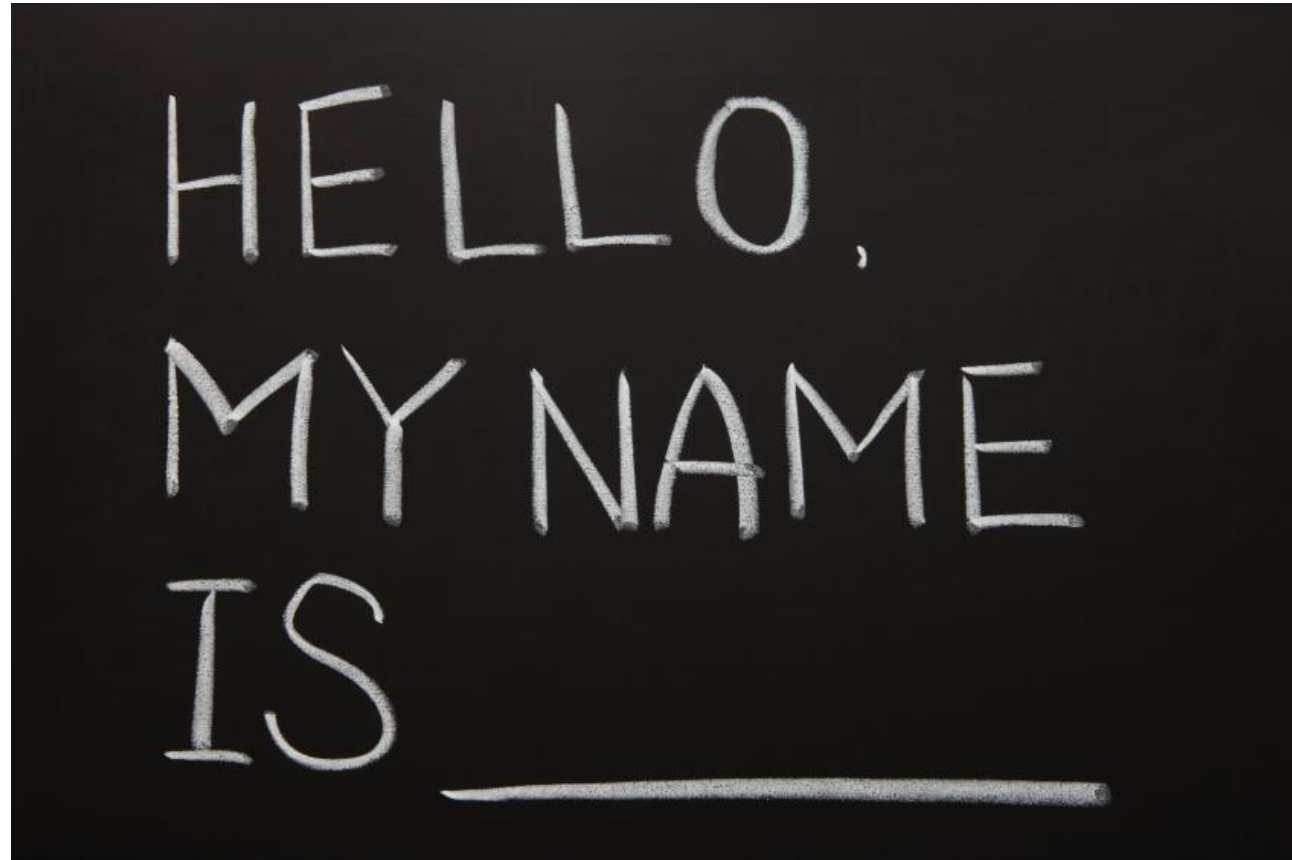

Aims and Objectives

Aims and Objectives

1. Understand WP and the challenge to support under-represented learners into higher education
2. How to identify & target WP Learners
3. The King's model & top tips



Q: What support can universities offer students, parents, teachers and social workers to support their educational journey?

Widening Participation

Agree or Disagree?

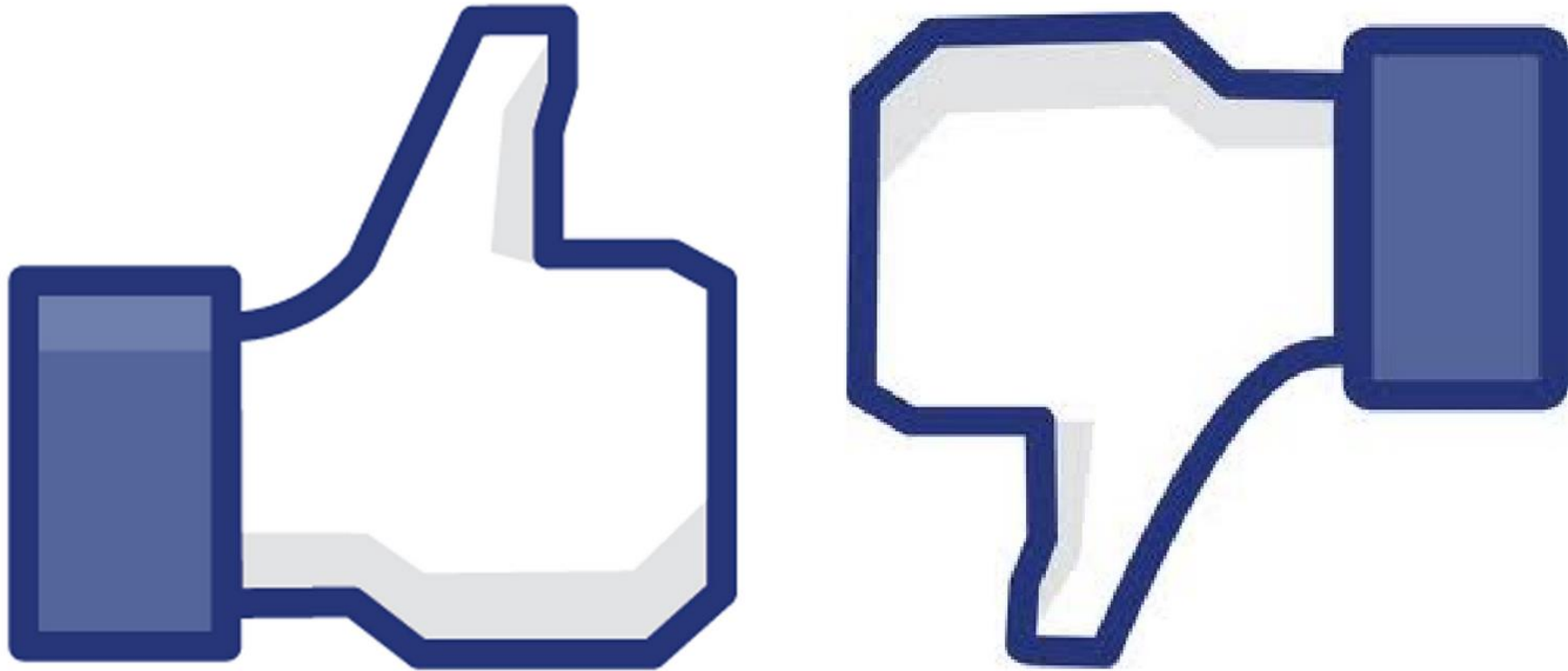

“University is for
everyone.”

“I will talk to younger
(under 14s) & older (21
or above) people about
university.”

“Parental engagement is
a critical factor in
widening access to
university.”

“A degree from Oxford
Brookes is just as
valuable as a degree
from the University of
Oxford.”

What is WP?

- In groups...



What is WP?

“The most disadvantaged 20% of young people are still **6.8 times** less likely to attend highly selective universities than the most advantaged 20%.”

Source: Office for Fair Access Strategic Plan, 2015

What is WP?

‘We will seek out and nurture talent to ensure that our pursuit of academic excellence is enriched by the diverse experiences of our students. Students from under-represented backgrounds will be supported to access higher education through high quality, innovative and effective widening participation schemes.’

What is WP?

‘We will seek out and nurture talent to ensure that our pursuit of academic excellence is enriched by the diverse experiences of our students. Students from under-represented backgrounds will be supported to access higher education through high quality, innovative and effective widening participation schemes.’

What is WP?

- Strategic priority for the UK government to restructure higher education based on equality
- Mostly university-led through collaboration with schools and other institutions
- Universities are relatively autonomous in deciding their WP strategy
- Accountability via an Access Agreement



What is WP?

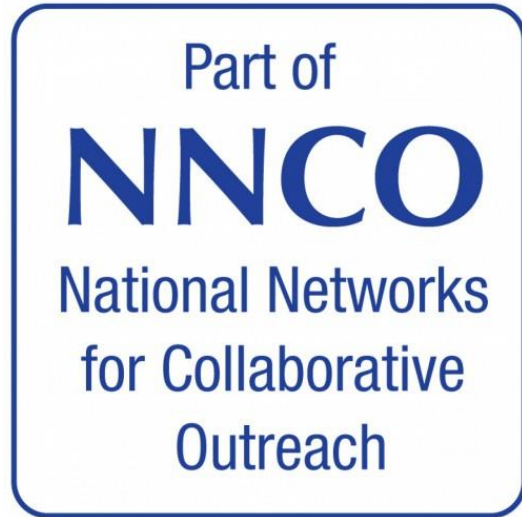

Targeting WP Learners

Activity A

Targeting support

1. On each post-it note, write down one group of people who are under-represented in Higher Education.
2. On another post-it note, write down how you would identify whether a student belonged to that group.

Assessing WP Status

First generation

**POLAR
ACORN
FSM**

School Performance

- Special status**
- LAC/ Care leaver
 - Asylum seeker
 - Estranged
 - Disability
 - Ethnicity
 - Gender

**Participation in WP
scheme**

Parental income

WP at King's

Programmes at King's



Stage 1	Stage 2	Stage 3	Stage 4	Stage 5
Pre-16 outreach	Post-16 outreach	Fair admissions	Positive student experience	Successful graduates
We will deliver aspiration-raising activities for local students that encourage higher education participation. King's outreach programmes will support informed choice-making through impartial guidance.	We will deliver targeted outreach work with students in London and beyond to improve access to King's College London and other universities. Activities will seek to enhance attainment and preparedness for higher study.	We will ensure that King's College's recruitment, selection and admissions processes are fair, transparent and identify the talent and potential of students from all backgrounds.	We will provide excellent student and education support services that seek to address the on-course needs of students from widening participation backgrounds.	We will deliver tailored support to improve the employability and career outcomes of students from widening participation backgrounds.

Our Aims



- Targeting and Evaluation
- London focus
- Commitment to encouraging education at King's & beyond
- Sustained Impact

K+

KING'S
College
LONDON

- Y12 and Y13 (Around 280 per year, 40 per stream)
- Variable Offer & Special Admissions Consideration
- Start-up Scholarship
- Eligibility:
 - Have achieved at least 8 A*-C grades at GCSE or equivalent, including English Language and Maths, with a minimum of 5 A or A* grades
 - Do not have parents or carers who have studied at university in the UK or abroad.
 - Study at a London-based state school



**Applications close
in one week.**

Join us, *London*

Apply now:
kplus.london

Deadline:
11th October

#kpluslondon
@kclwp f /kclwp

KING'S
College
LONDON

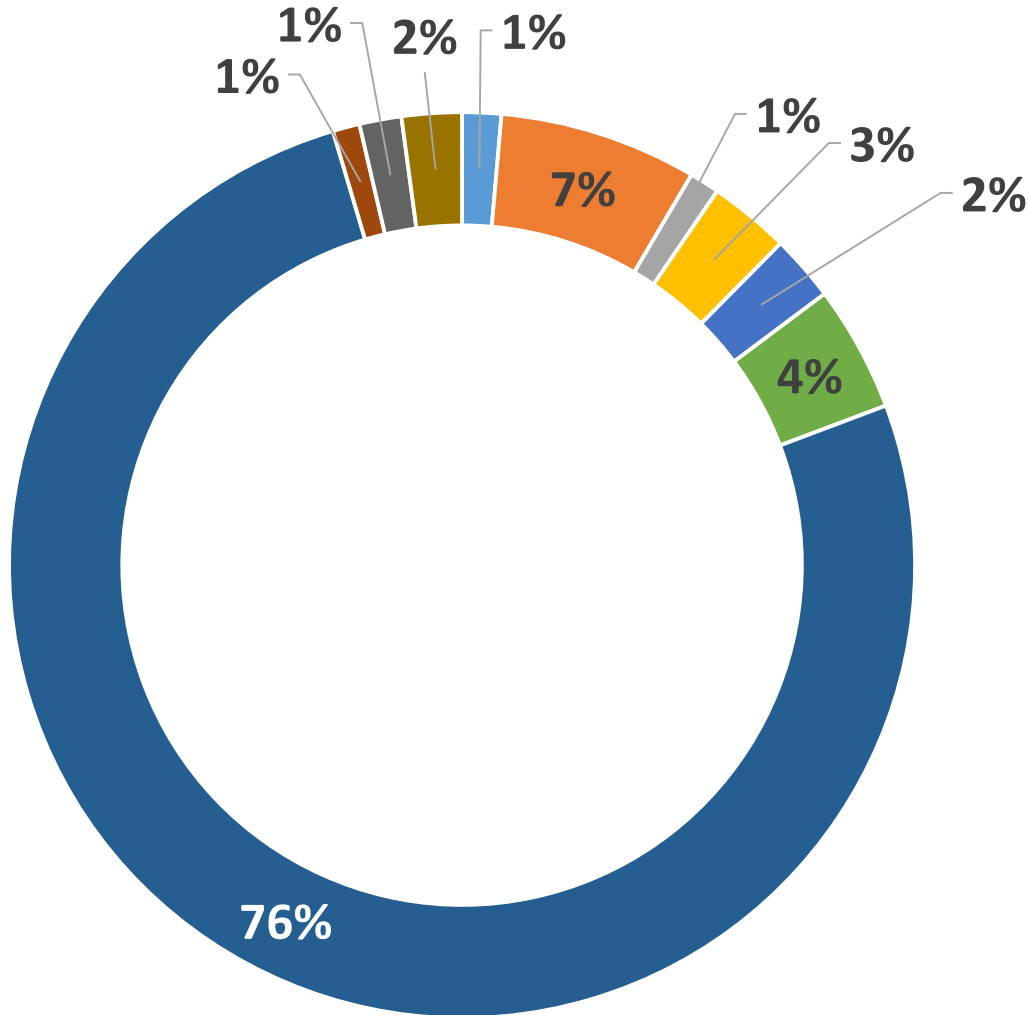

- A family member told me
- **A friend told me**
- A K+ postcard at my school/college
- A K+ poster in my school/college
- Another student who is currently on K+ spoke at my school/college
- **I found it by searching on the internet**
- **My teacher or a member of school/college staff told me**
- Other
- Someone from King's spoke at my school/college
- Someone who's already on the programme told me

King's Scholars

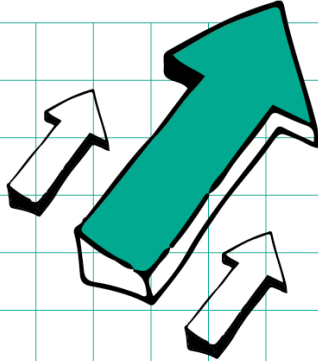

King's
Scholars

Helping young people explore
university and beyond

Gameplan.ac.uk



Advancing Access



- Virtual Conferences
- Case Studies
- Webinars
- Classroom Materials, Presentations & Activities
- Advice, Guidance & Other Resources
- Links to universities

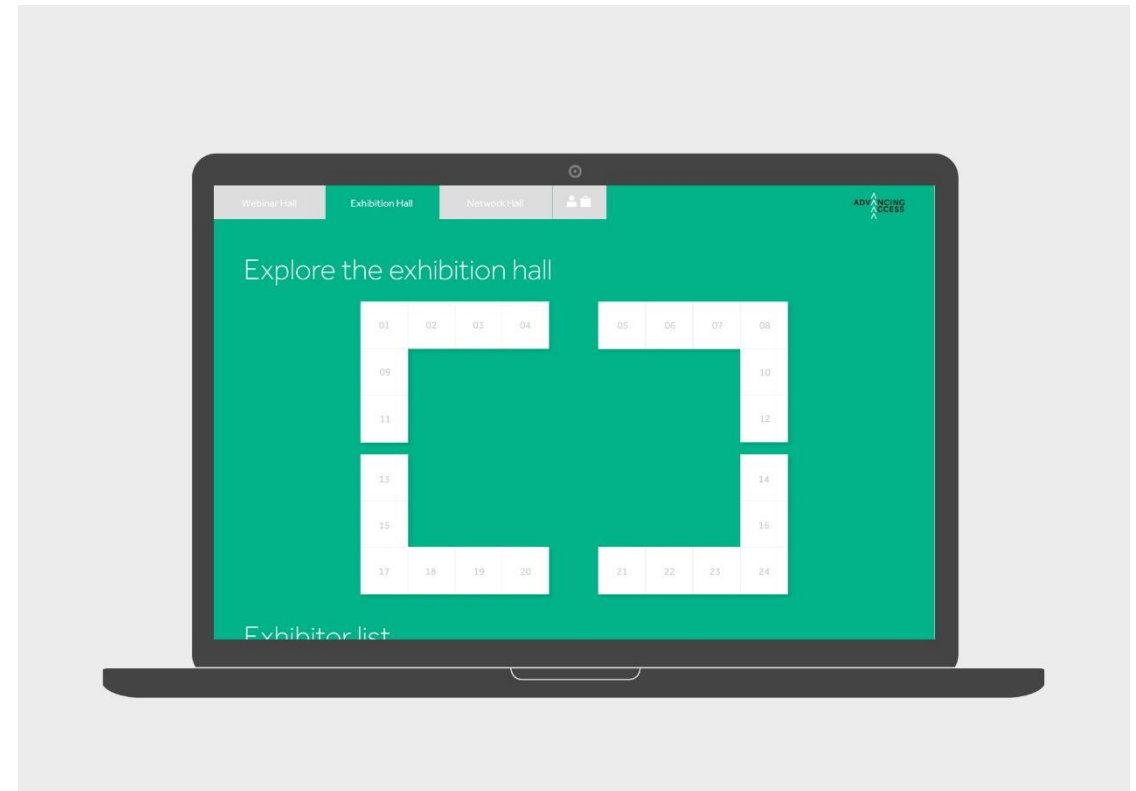

King's Advocate Award

Aims

- Support access
- Increase engagement
- Create school links
- Establish a network
- Introduce best practice



King's Advocate Award



Benefits

- CPD
- £500 start-up bursary*
- Project Grant
- Join a network of teachers across London
- Official recognition from King's College London

Next Steps

Stakeholder mapping

Team building and increasing capacity

List all of the individuals who are currently, or should be, engaged in the work of widening participation.

Consider and discuss ...

Low commitment and support
High influence

High commitment and support
High influence

Low commitment and support
Low influence

High commitment and support
Low influence

Building a programme of activity

	Year 10	Year 11	Year 12	Year 13
January				
February				
March				
April				
May				
June				
July				
August				
September				
October				
November				
December				

One thing you will do

One thing you will share

Thank you